

Ficha Técnica

Berkel PRO LINE XS 25-30

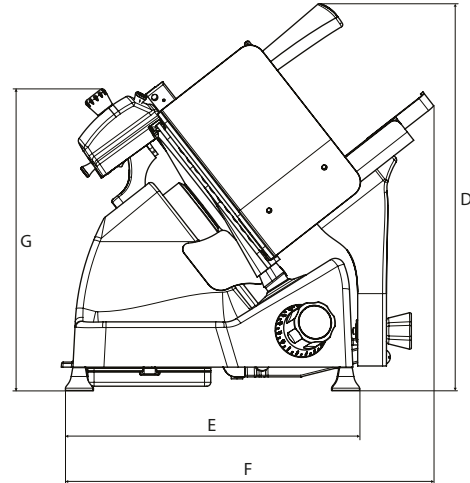
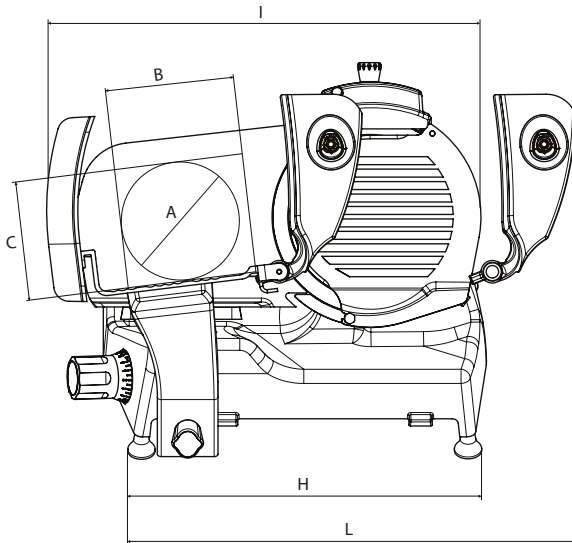

Especificaciones Técnicas

	XS 25	XS 30
∅ Diámetro de la cuchilla	250 mm	300 mm
Espesor de corte:	0 - 14 mm	0 - 14 mm
Capacidad de corte circular	188 mm	230 mm
Capacidad de corte rectangular	225X178 mm	245X195 mm
Peso neto	19 kg	29 kg
Potencia del motor	0,33 kW	0,35 kW
Especificaciones eléctricas:	230 V 50 Hz 1 PH 230 V 50 Hz 1 PH	

Dimensiones (mm)

XS 25	XS 30
A 188 mm	A 230 mm
B 225 mm	B 245 mm
C 178 mm	C 195 mm
D 505 mm	D 545 mm
E 378 mm	E 415 mm
F 480 mm	F 595 mm
G 445 mm	G 435 mm
H 450 mm	H 506 mm
I 565 mm	I 640 mm
L 575 mm	L 645 mm

www.masrefrigeracion.mx



MAS REFRIGERACION Y EQUIPOS
 AV. MADERO 2116 COL. OBRERA, MONTERREY, NL. TEL. 81 8191 9050